

# TSB65R700S1

## 650V 7A N-Channel SJ-MOSFET

### General Description

Truesemi SJ-FET is new generation of high voltage MOSFET family that is utilizing an advanced charge balance mechanism for outstanding low on-resistance and lower gate charge performance.

This advanced technology has been tailored to minimize conduction loss, provide superior switching performance, and withstand extreme dv/dt rate and higher avalanche energy.

SJ-FET is suitable for various AC/DC power conversion in switching mode operation for higher efficiency.

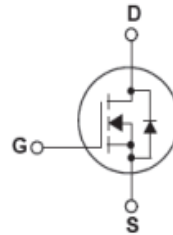
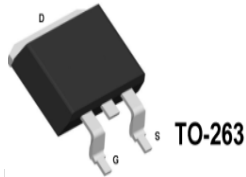

### Features

- 700V @T<sub>J</sub> = 150 °C
- Typ. R<sub>DS(on)</sub> = 0.6Ω
- Ultra Low gate charge (typ. Q<sub>g</sub> = 25nC)
- 100% avalanche tested

### Absolute Maximum Ratings

Symbol	Parameter	Value	Unit
V <sub>DSS</sub>	Drain-Source Voltage	650	V
I <sub>D</sub>	Drain Current -Continuous (TC = 25°C) -Continuous (TC = 100°C)	7 4.6	A
I <sub>DM</sub>	Drain Current – Pulsed (Note 1)	18	A
V <sub>GSS</sub>	Gate-Source voltage	±30	V
E <sub>AS</sub>	Single Pulsed Avalanche Energy (Note 2)	86	mJ
I <sub>AR</sub>	Avalanche Current (Note 1)	1.7	A
E <sub>AR</sub>	Repetitive Avalanche Energy (Note 1)	0.2	mJ
dv/dt	Peak Diode Recovery dv/dt (Note 3)	15	V/ns
P <sub>D</sub>	Power Dissipation (TC = 25°C) -Derate above 25°C	63 1.67	W
T <sub>J</sub> , T <sub>STG</sub>	Operating and Storage Temperature Range	-55 to +150	°C
T <sub>L</sub>	Maximum Lead Temperature for Soldering Purpose, 1/8" from Case for 5 Seconds	300	°C

\* Drain current limited by maximum junction temperature.

### Thermal Characteristics

Symbol	Parameter	Value	Unit
R <sub>θJC</sub>	Thermal Resistance, Junction-to-Case	2.0	°C/W
R <sub>θCS</sub>	Thermal Resistance, Case-to-Sink Typ.	0.5	°C/W
R <sub>θJA</sub>	Thermal Resistance, Junction-to-Ambient	62	°C/W

## Electrical Characteristics TC = 25 °C unless otherwise noted

Symbol	Parameter	Conditions	Min	Typ	Max	Unit
Off Characteristics						
$BV_{DSS}$	Drain-Source Breakdown Voltage	$V_{GS} = 0V, I_D = 250\mu A, T_J = 25^\circ C$	650	--	--	V
		$V_{GS} = 0V, I_D = 250\mu A, T_J = 150^\circ C$	--	700	--	V
$\Delta BV_{DSS} / \Delta T_J$	Breakdown Voltage Temperature Coefficient	$I_D = 250\mu A$ , Referenced to 25 °C	--	0.6	--	V/°C
$I_{DSS}$	Zero Gate Voltage Drain Current	$V_{DS} = 650V, V_{GS} = 0V, -T_J = 150^\circ C$	--	--	1 10	$\mu A$ $\mu A$
$I_{GSSF}$	Gate-Body Leakage Current, Forward	$V_{GS} = 30V, V_{DS} = 0V$	--	--	100	nA
$I_{GSSR}$	Gate-Body Leakage Current, Reverse	$V_{GS} = -30V, V_{DS} = 0V$	--	--	-100	nA
On Characteristics						
$V_{GS(th)}$	Gate Threshold Voltage	$V_{DS} = V_{GS}, I_D = 250\mu A$	2.5	3.5	4.5	V
$R_{DS(on)}$	Static Drain-Source On-Resistance	$V_{GS} = 10V, I_D = 3.5A$	--	0.6	0.7	$\Omega$
$g_{FS}$	Forward Trans conductance	$V_{DS} = 40V, I_D = 3.5A$ (Note 4)	--	16	--	S
Dynamic Characteristics						
$C_{iss}$	Input Capacitance	$V_{DS} = 25V, V_{GS} = 0V, f = 1.0MHz$	--	380	--	pF
$C_{oss}$	Output Capacitance		--	110	--	pF
$C_{rss}$	Reverse Transfer Capacitance		--	7	--	pF
$t_{d(on)}$	Turn-On Delay Time	$V_{DD} = 400V, I_D = 3.5A, R_G = 20\Omega$ (Note 4 , 5)	--	13	--	ns
$t_r$	Turn-On Rise Time		--	10	--	ns
$t_{d(off)}$	Turn-Off Delay Time		--	85	--	ns
$t_f$	Turn-Off Fall Time		--	14	--	ns
$Q_g$	Total Gate Charge	$V_{DS} = 480V, I_D = 3.5A, V_{GS} = 10V$ (Note 4,5)	--	25	--	nC
$Q_{gs}$	Gate-Source Charge		--	2.0	--	nC
$Q_{gd}$	Gate-Drain Charge		--	2.7	--	nC
Drain-Source Diode Characteristics and Maximum Ratings						
$I_S$	Maximum Continuous Drain-Source Diode Forward Current		--	--	7	A
$I_{SM}$	Maximum Pulsed Drain-Source Diode Forward Current		--	--	18	A
$V_{SD}$	Drain-Source Diode Forward Voltage	$V_{GS} = 0V, I_F = 3.5A$	--	0.9	1.5	V
$t_{rr}$	Reverse Recovery Time	$V_{GS} = 0V, I_F = 3.5A, di_F/dt = 100A/\mu s$ (Note 4)	--	190	--	ns
$Q_{rr}$	Reverse Recovery Charge		--	2.3	--	$\mu C$

**NOTES:**

1. Repetitive Rating: Pulse width limited by maximum junction temperature
2. L=60mH,  $I_{AS}=1.7A, V_{DD}=50V$ , Starting  $T_J=25^\circ C$
3.  $I_{SD} \leq 7A, di/dt \leq 200A/\mu s, V_{DD} \leq BV_{DSS}$ , Starting  $T_J = 25^\circ C$
4. Pulse Test: Pulse width  $\leq 300\mu s$ , Duty Cycle  $\leq 2\%$
5. Essentially Independent of Operating Temperature Typical Characteristics

# Typical Performance Characteristics

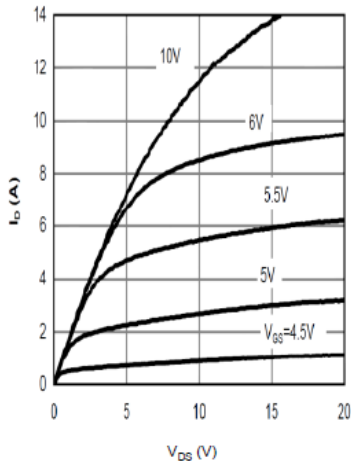

Figure 1: On-Region Characteristics@25°C

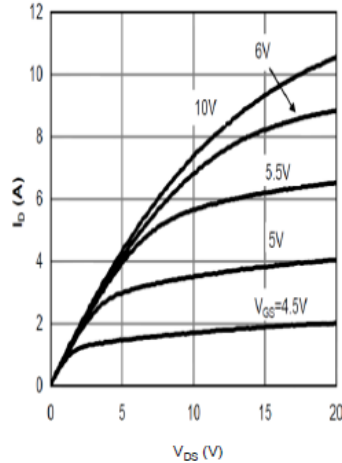

Figure 2: On-Region Characteristics@125°C

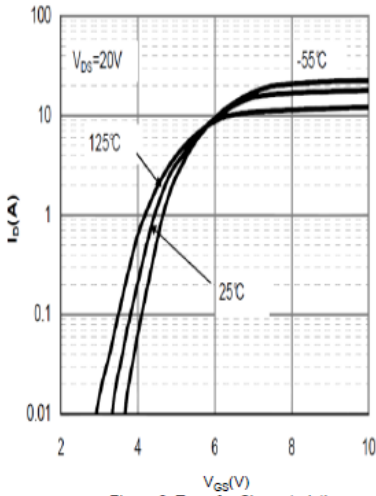

Figure 3: Transfer Characteristics

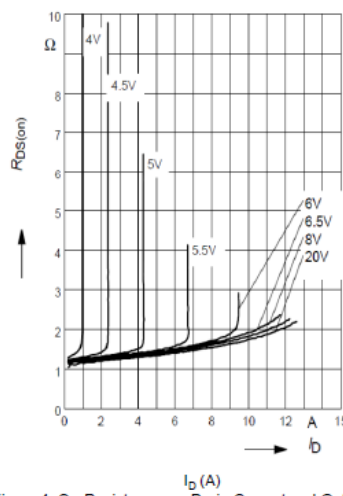

Figure 4: On-Resistance vs. Drain Current and Gate Voltage

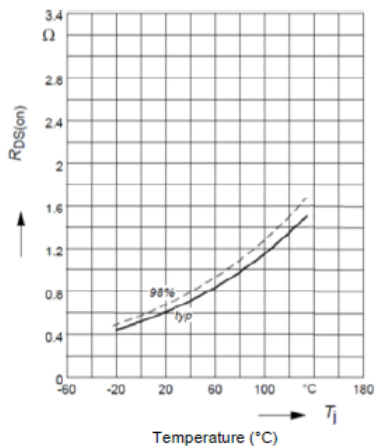

Figure 5: On-Resistance vs. Junction Temperature

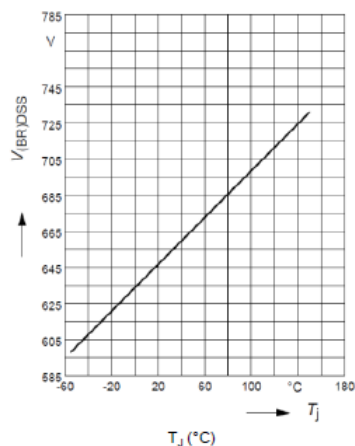

Figure 6: Break Down vs. Junction Temperature

# Typical Performance Characteristics

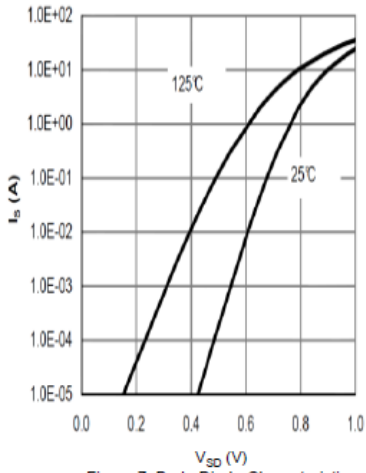

Figure 7: Body-Diode Characteristics

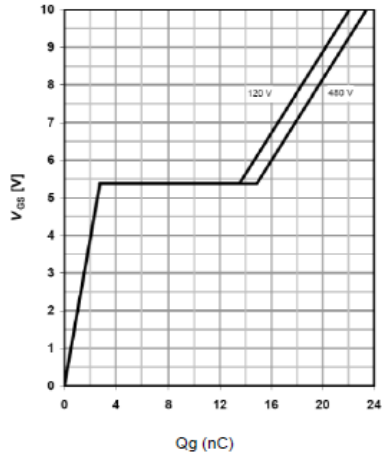

Figure 8: Gate-Charge Characteristics

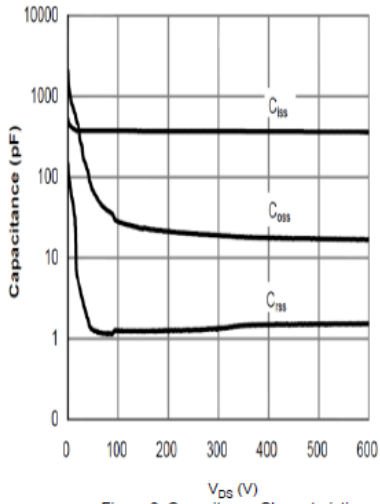

Figure 9: Capacitance Characteristics

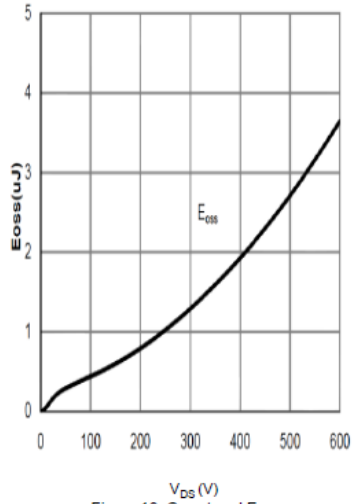

Figure 10:  $C_{oss}$  stored Energy

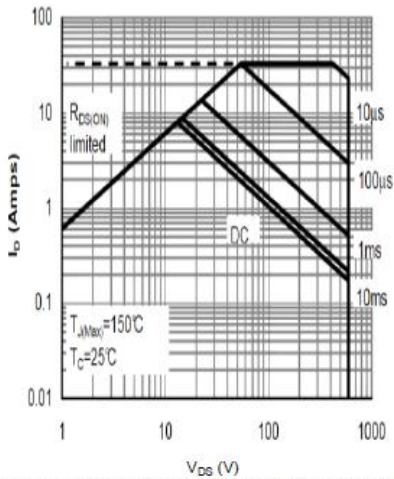

Figure 11: Maximum Forward Biased Safe Operating Area

# Typical Performance Characteristics

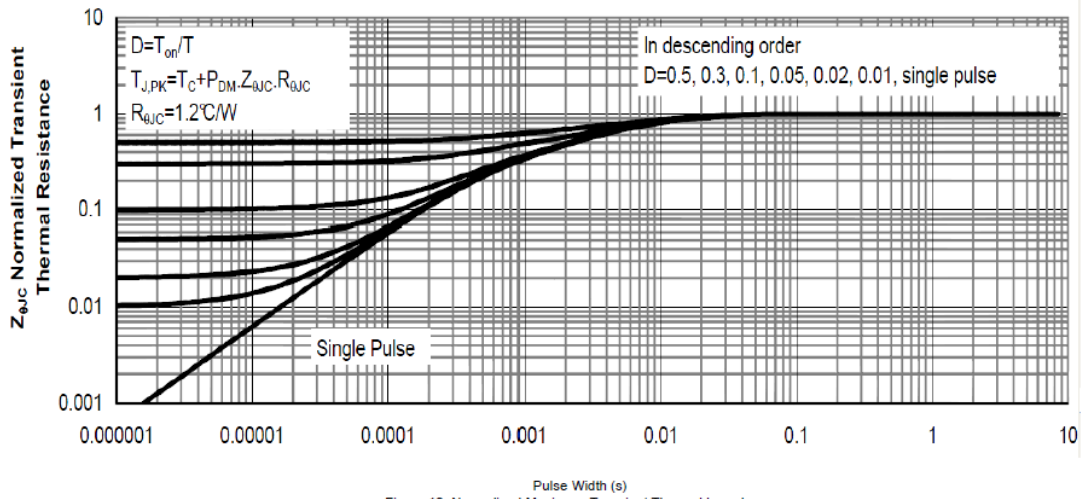

Figure 12: Normalized Maximum Transient Thermal Impedance

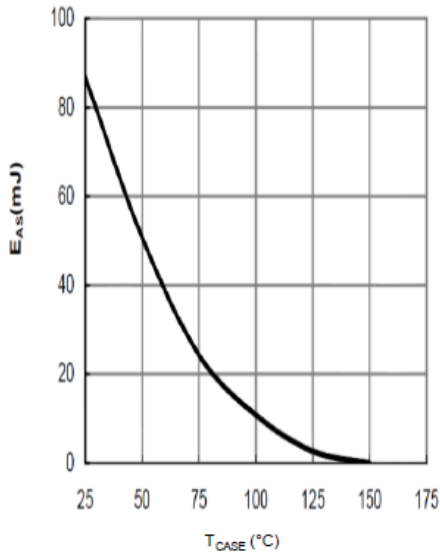

Figure 13: Avalanche energy

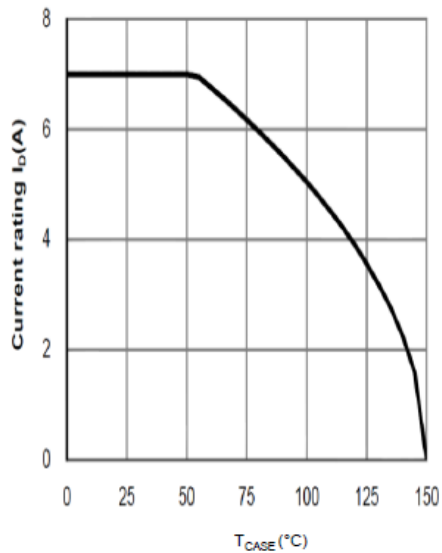

Figure 14: Current De-rating

# Typical Performance Characteristics

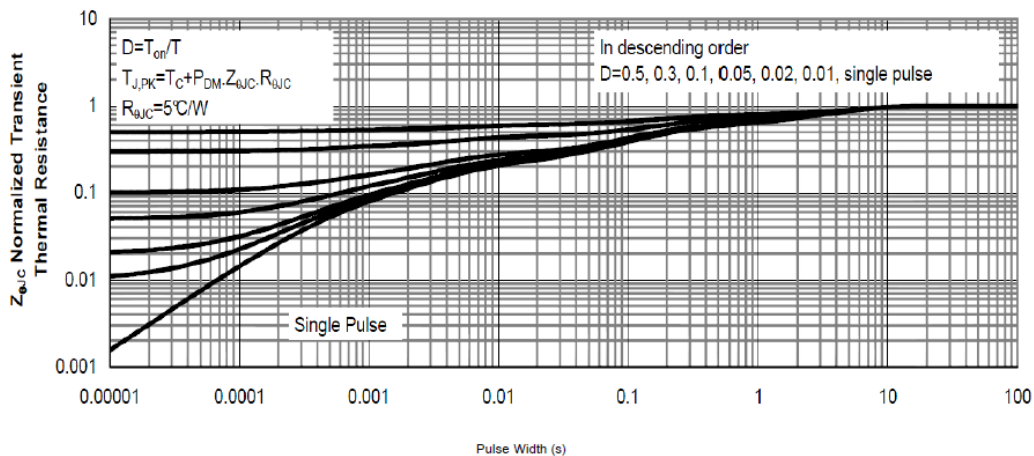
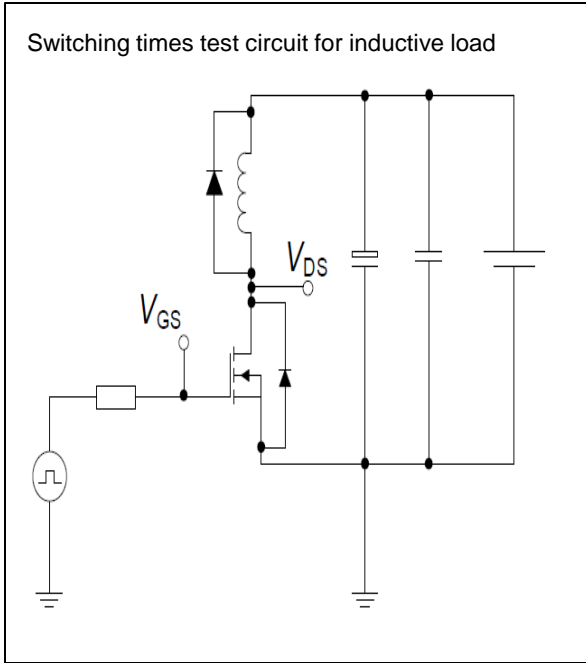

Figure 15: Normalized Maximum Transient Thermal Impedance

# Test circuits

## Switching times test circuit and waveform for inductive load



## Unclamped inductive load test circuit and waveform



# Test circuits

## Test circuit and waveform for diode characteristics

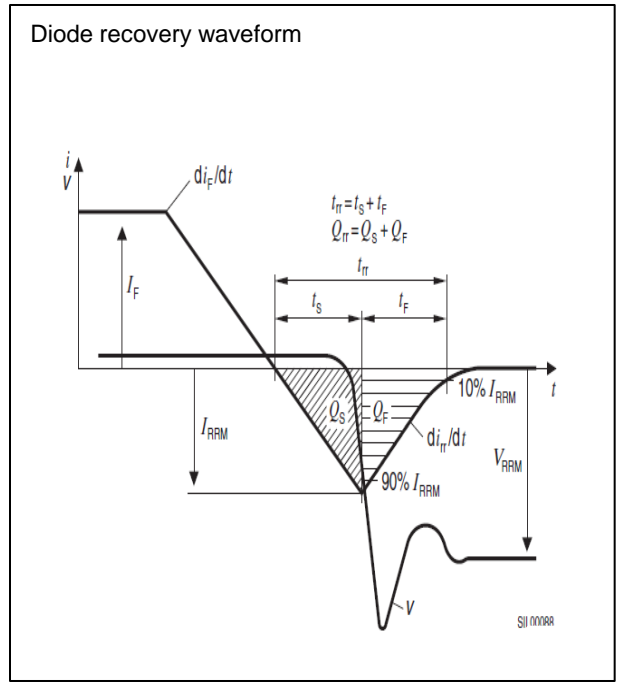
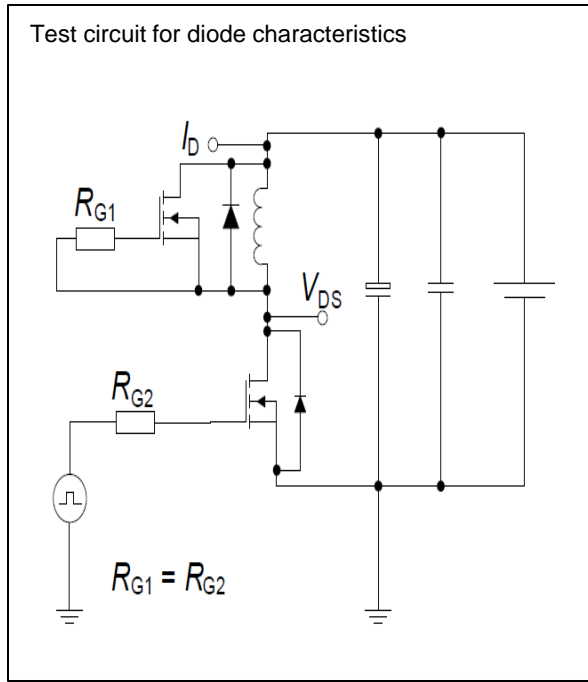



# Package Outline TO-263

TSB65R700S1 650V 7A N-Channel SJ-MOSFET

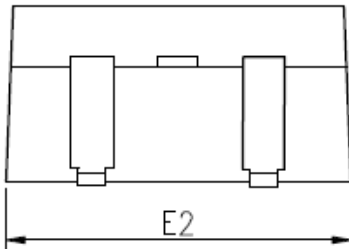
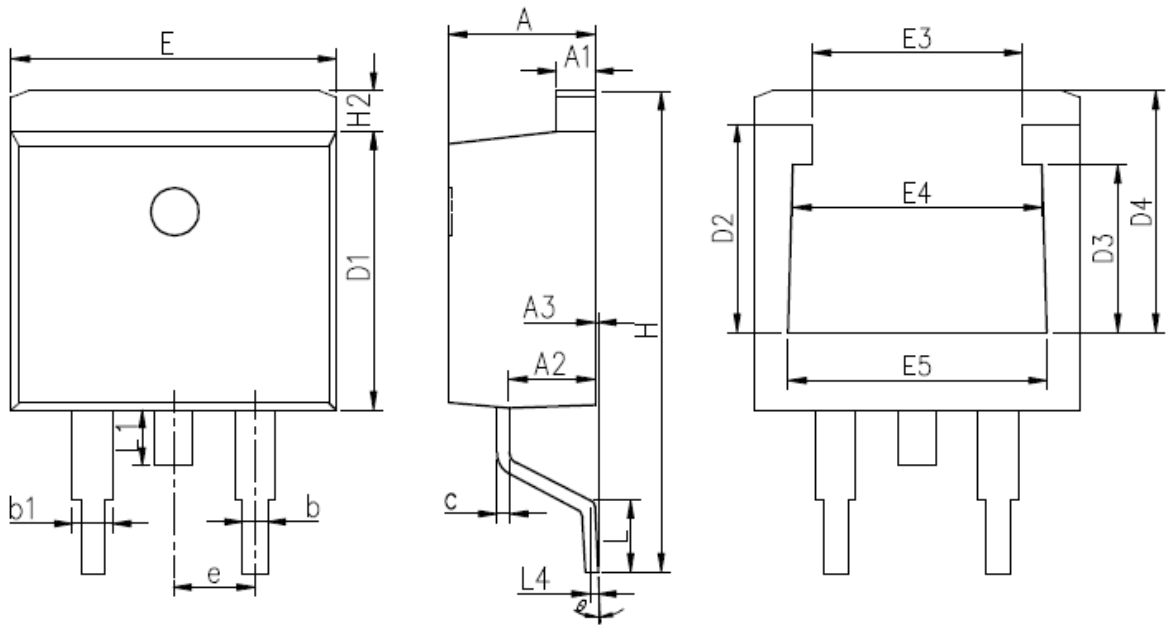

## COMMON DIMENSIONS

SYMBOL	MM		
	MIN	NOM	MAX
A	4.27	4.57	4.87
A1	1.22	1.27	1.42
A2	2.39	2.69	2.99
A3	0.00	0.13	0.20
b	0.70	0.81	1.01
b1	1.17	1.27	1.50
c	0.30	0.38	0.53
D1	8.40	8.70	9.00
D2	5.33	6.33	6.63
D3	4.54	5.54	5.84
D4	6.60	7.60	8.00
E	9.88	10.16	10.50
E2	9.80	10.10	10.40
E3	4.94	5.94	6.24
E4	6.67	7.67	7.97
E5	7.06	8.06	8.36
e	2.54 BSC		
H	14.70	15.10	15.50
H2	1.00	1.27	1.50
L	2.00	2.30	2.60
L1	1.35	1.55	1.75
L4	0.25 BSC		
$\theta$	0°	5°	9°